



TrussBRACE

Roof Truss Support



Installation Guide

This simple 6-step TrussBRACE approach completes both temporary lateral restraint and diagonal bracing of the top chord and web member plane. Additional bracing may be required per the construction documents and truss design drawings.

Prior to truss installation please review the following checklist to ensure:

1. Building dimensions match the construction documents.
2. Bearing supports are accurately and securely installed.
3. Load bearing supports (e.g., walls, columns, headers, beams, etc.) are plumb and properly braced.
4. Hangers, tie-downs, restraint, and bracing materials are on site and accessible.
5. Erection/installation crew is aware of installation plan and lateral restraint/diagonal bracing requirements.
6. Multi-ply trusses, including girders, are correctly fastened together prior to lifting into place.
7. Any truss damage is reported to truss manufacturer. Do not install damaged trusses unless instructed to do so by the building designer, truss designer, or truss manufacturer.
8. Trusses are the correct dimension.
9. Tops of bearing supports are flat, level, and at the correct elevation.
10. Jobsite is clean and free of obstructions.

Read this guide completely before starting installation and remember to:

- Keep trusses straight during hoisting to minimize bending out-of-plane.
- Secure the first truss onto the building.
- Ensure that each of the first three trusses making up the 3-truss assembly are plumb.
- Assemble the first three trusses with all TrussBRACES and diagonal bracing, as shown, so that the 3-truss assembly is stable.

Important Reminders:

- Do not walk on TrussBRACES or use to support bodyweight.
- Do not remove TrussBRACES for future use.
- Do not use TrussBRACES that have been bent, kinked, or otherwise damaged.
- Pinch points and sharp edges can cause injuries. Use proper personal protective equipment when installing TrussBRACES.
- TrussBRACES can only be installed with trusses that are placed 24" on-center and up to 60' in length.
- Spans over 60' require more complex temporary installation restraint/diagonal Bracing. Consult a professional engineer.



For alternate language installation guides visit FastenMaster.com
 Pour obtenir les guides d'installation dans d'autres langues, accédez à FastenMaster.com
 Ingresa en FastenMaster.com para obtener guías de instrucciones de instalación en otros idiomas

STEP 1: TRUSS SPACING

Determine TrussBRACE spacing (based on truss span) using Table 1.

- As a general practice, TrussBRACES should be installed on the top chords or webs along the trusses at the spacing shown in Table 1.
- When the top chord can no longer be conveniently reached (approximately 5.5' to 6.5'), apply the TrussBRACES to the next web member that is within the Table 1 spacing limits.

Table 1. TrussBRACE Spacing per Truss Span	
Truss Span	TrussBRACE Spacing
Up to 30'	12' on center max.
30' – 45'	10' on center max.
45' to 60'	8' on center max.

Note: The example in the guide (fig 1.1) uses 40' trusses with a maximum height of 10'. Therefore, the required TrussBRACE spacing is every 10' on center, with TrussBRACE at locations 1 and 3 installed on the top chords and TrussBRACE at location 2 installed on the webs, as illustrated.

The diagonal bracing shown is added in STEP 2. In locations 1 and 3, it is placed in the web members underneath the TrussBRACES. In location 2 it is placed either over top of the TrussBRACES in the web member plane or on the other side of the webs opposite the TrussBRACE (fig 2.1).

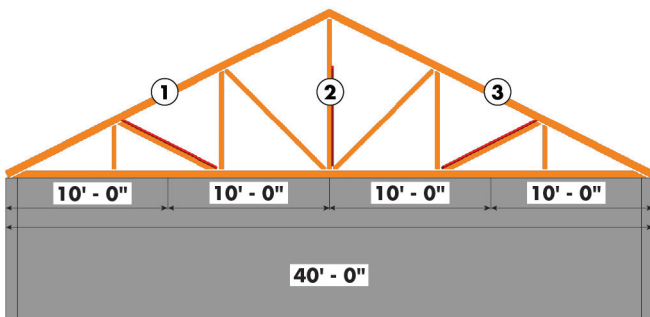
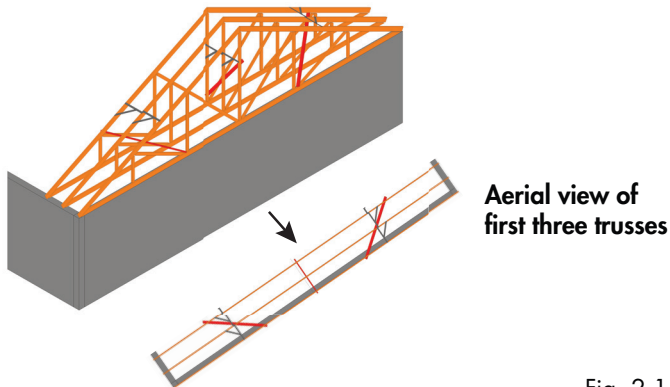

Fig. 1.1

STEP 2: SET FIRST THREE TRUSSES

Set the first three trusses with TrussBRACE as shown in visual guide to create a stable foundation for the structure (fig 2.1).

- At minimum, use three (3) 10d common (0.148" x 1.5") nails: one on each end of the lateral leg and the third on the diagonal leg (fig 2.2).
- Drive nails completely so the TrussBRACE is tight to the truss.
- Apply diagonal bracing as shown (red members) to stabilize the 3-truss-set after trusses are set and TrussBRACE are installed.



Aerial view of first three trusses

Fig. 2.1

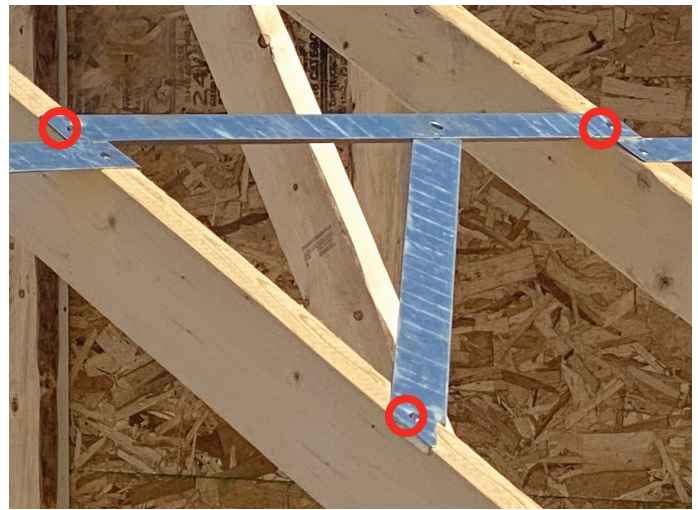

Fig. 2.2

Note: Fig 2.2 TrussBRACE Installed in Top Chord Application (circles indicate nailing locations).

STEP 3: SET REMAINING TRUSSES

Working from the bottom chords, (fig 3.1) set trusses 4 through 15 in line with the TrussBRACE placed on the first 3 trusses (fig 3.2).

- When the top chord can no longer be conveniently reached (approximately 5.5' to 6.5'), apply the TrussBRACE to the next web member that is within the Table 1 spacing limits or requires lateral restraint per the truss design drawing (fig 3.2).



Fig. 3.1

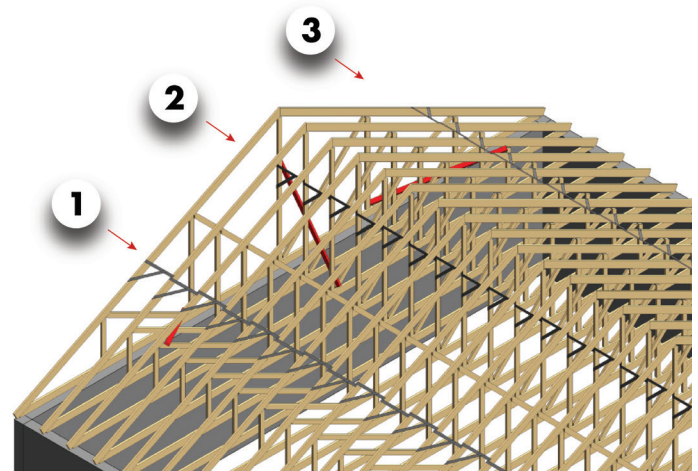

Fig. 3.2

STEP 4: APPLY WEB MEMBER

Apply web member diagonal bracing as shown in red in the visual guide after truss 15 has been set (fig 2.1).

Note: If fewer than 30 trusses are being used, apply diagonal bracing at midway point in truss installation (e.g., if setting 20 trusses, apply bracing after truss 10 is set).



STEP 5: COMPLETE INSTALLATION

Repeat steps 3 and 4 until the entire roof system is set (fig 5.1).



Fig. 5.1

STEP 6: APPLY SHEATHING

Apply structural sheathing to the top chord of all the trusses directly over the TrussBRACE (fig 6.1).

Note: Ground bracing is not shown for clarity. Refer to BCSI for additional information.

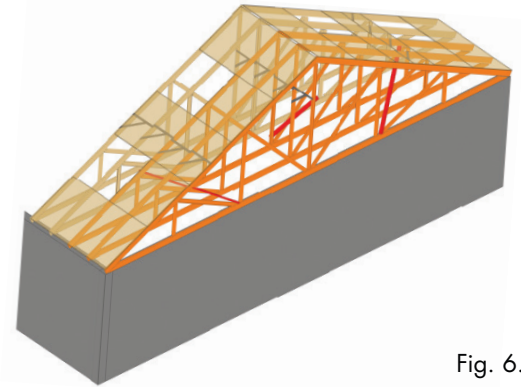

Fig. 6.1

FastenMaster TrussBRACE Limited Warranty

FastenMaster warrants the FastenMaster TrussBRACE (the "Product") to be free from defects in materials and workmanship for the life of the truss on which it is installed. When used as recommended by FastenMaster and installed in accordance with the manufacturer's instructions for the materials being attached, the coating and structural performance of the Product is covered by this limited warranty. This installation guide outlines methods and procedures intended to ensure that trusses are SAFELY installed using the FastenMaster TrussBRACE system.

The recommendations for the FastenMaster TrussBRACE restraint and diagonal bracing of trusses provided in this guide are based on testing that compared its performance to standard industry bracing specifications. This testing was performed in an IST/IEC 17025 accredited test facility. This installation guide includes a step-by-step process for installing the product that begins with a three-truss assembly intended to provide a stable set of trusses onto which each subsequent truss is attached using the FastenMaster TrussBRACE. For additional information about proper handling, installing, restraining, and bracing trusses, please refer to the Building Component Safety Information ("BCSI") guide to good practice for handling, installing, restraining & bracing of metal plate connected wood trusses.

This installation guide is provided for use by a qualified truss installer and crane operator (if applicable). If the contractor believes that he or she needs assistance installing the FastenMaster TrussBRACE system, he or she should seek assistance from the building designer. This installation guide and the BCSI are not intended to supersede the building designer's design specifications for handling, installing, restraining, and bracing trusses, and they do not preclude the use of other equivalent methods for restraining and bracing trusses.

This limited warranty covers only the cost of replacement of defective FastenMaster TrussBRACE Product, and only when the product is installed in accordance with this installation guide, BCSI guidelines, the building designer's design specifications, and all applicable building codes and other laws. Claims under this limited warranty must be made within 60 days of discovering the failure of the product, and claims should be submitted in writing to <https://www.fastenmaster.com/support>. Questions about the product, the claims process or installation of the products should be directed to FastenMaster technical support at 1-800-518-3569. Claims related to failures or defects that are determined (by FastenMaster, in its sole discretion) to be the result of improper use or installation of the product will not be honored and this limited warranty will not apply.

The claim process may require the claimant to submit one or more of the following prior to resolution: proof of purchase, a detailed description of the application and failure type, pictures and samples of the problem fasteners. This warranty covers only the cost of the FastenMaster product affected. Building materials and other costs and/or damages, such as decking, framing and accessories and the labor to remove or replace affected product are not covered under this limited warranty. FastenMaster will not be liable for any consequential, incidental, special or punitive damages, lost profits, delays, or repair or rework costs.



FastenMaster® is a registered trademark of OMG, Inc. Copyright © 2022. U.S. Patent Pending.
OMG, Inc. 153 Bowles Road, Agawam, MA 01001 800-518-3569 FastenMaster.com