



**OMG, INC.**  
**153 Bowles Road**  
**Agawam, MA 01001**  
**(800) 518-3569**  
[www.olyfast.com](http://www.olyfast.com)  
[www.fastenmaster.com](http://www.fastenmaster.com)

### **FASTENMASTER® FRAMEFAST® FASTENERS**

**CSI Division: 06 00 00 – Wood, Plastics, and Composites**  
**CSI Section: 06 05 23 – Wood, Plastic, and Composite Fastenings**

#### **1.0 SCOPE OF EVALUATION**

##### **1.1 Compliance to the following codes & regulations:**

- 2021, 2018, 2015, and 2012 International Building Code® (IBC)
- 2021, 2018, 2015, and 2012 International Residential Code® (IRC)
- 2023 City of Los Angeles Building Code (LABC) – attached Supplement
- 2023 City of Los Angeles Residential Code (LARC) – attached Supplement
- 2023 Florida Building Code, Building (FBC, Building) – attached Supplement
- 2023 Florida Building Code, Residential (FBC, Residential) – attached Supplement

##### **1.2 Evaluated in accordance with:**

- ICC-ES AC233
- ICC-ES AC257

##### **1.3 Properties assessed:**

- Structural
- Corrosion Resistance

#### **2.0 PRODUCT USE**

The FastenMaster® FrameFAST® Fastener is used as dowel-type threaded fasteners used for wood-to-wood connections.

The FastenMaster® FrameFAST® Fastener may be used where fasteners are required to exhibit corrosion resistance when exposed to adverse environmental conditions and/or in chemically treated wood, which are subject to limitations in Section 5.5 of this report, and are alternatives to hot-dipped-zinc-coated galvanized fasteners with a coating weight in compliance with ASTM A153, Class D. The fastener was evaluated for contact with wood chemically treated with waterborne alkaline copper quaternary, Type D (ACQ-D).

#### **3.0 PRODUCT DESCRIPTION**

**3.1 General:** The FastenMaster® FrameFAST® Fastener described in this report is partially rolled-threaded and has a proprietary point as shown in Figure 1 of this report. The

fastener is available in a 6-inch length as described in Table 1 of this report.

#### **3.2 Materials**

**3.2.1 FrameFAST® Fastener:** The FastenMaster® FrameFAST® Fasteners are produced from Grade 10B21 carbon steel complying with ASTM A510. The fasteners are produced using a cold-forming process followed by heat treatment.

**3.2.2 Wood Members:** Wood side and main members shall consist of sawn lumber with a specific gravity of 0.42 to 0.55. The combined thickness of the main and side members shall be equal to or greater than the fastener length. Chemicals used to preservative treat wood are limited to the items described in Section 4.1.5 and Table 5 of this report.

#### **4.0 DESIGN AND INSTALLATION**

##### **4.1 Design:**

**4.1.1 General:** The connections using FastenMaster® FrameFAST® Fasteners shall be designed in accordance with the IBC or IRC. The fasteners may also be used where an engineering design is submitted in accordance with Section R301.1.3 of the IRC. Reference withdrawal, pull-through, and lateral design values in this report are for allowable stress design (ASD) and shall be multiplied by the applicable adjustment factors specified in the ANSI/AWC NDS (ANSI/AWC NDS) and this report to determine adjusted design values.

The allowable load for a single-fastener connection in which the fastener is subject to tension is the least of: (a) the reference withdrawal design value given in Table 2 of this report, adjusted by all applicable adjustment factors; (b) the reference head pull-through design value given in Table 2 of this report, adjusted by all applicable adjustment factors; and (c) the allowable fastener tension strength given in Table 1 of this report.

The allowable lateral load for a single-fastener connection is the lesser of: (a) the reference lateral design values given in Table 3 of this report, adjusted by all applicable adjustment factors, and (b) the allowable fastener shear strength given in Table 1 of this report.

Where the fasteners are subject to combined lateral and withdrawal loads, connections shall be designed in accordance with Section 12.4.1 of the 2018 or 2015 ANSI/AWC NDS, or Section 11.4.1 of the 2012 ANSI/AWC NDS, as applicable.

Connections containing multiple fasteners shall be designed in accordance with Sections 11.2.2 and 12.6 of the 2018 or 2015 ANSI/AWC NDS, or Sections 10.2.2 and 11.6 of the 2012 ANSI/AWC NDS, as applicable. When designing a connection, the structural members shall be checked for load-

*The product described in this Uniform Evaluation Service (UES) Report has been evaluated as an alternative material, design or method of construction in order to satisfy and comply with the intent of the provision of the code, as noted in this report, and for at least equivalence to that prescribed in the code in quality, strength, effectiveness, fire resistance, durability and safety, as applicable, in accordance with IBC Section 104.11. This document shall only be reproduced in its entirety.*





carrying capacity in accordance with Section 11.1.2 of the 2018 or 2015 ANSI/AWC NDS, or Section 10.1.2 of the 2012 ANSI/AWC NDS, as applicable, and local stresses within the connection shall be checked against Appendix E in the ANSI/AWC NDS to ensure the capacity of the connection and fastener group.

**4.1.2 Withdrawal:** Reference withdrawal design values for FastenMaster® FrameFAST® Fastener are given in Table 2 of this report in pounds per inch of thread penetration into the main member.

**4.1.3 Pull-Through:** Reference pull-through design values for FastenMaster® FrameFAST® Fasteners are given in Table 2 of this report in pounds per inch of thread penetration into the side member.

**4.1.4 Lateral:** Reference lateral design values for FrameFAST® Fasteners for single shear wood-to-wood connections loaded perpendicular-to-grain or parallel-to-grain are given in Table 3 of this report.

**4.1.5 Corrosion Resistance:** The FastenMaster® FrameFAST® Fastener has corrosion-resistant coatings that are recognized for use in wood members with chemical treatments limited to alkaline copper quaternary, Type D (ACQ-D), with a maximum retention level of 0.40 pcf (6.4 kg/m<sup>3</sup>). The fastener shall be limited to use in applications described in Section 5.5 and Table 5 of this report.

**4.2 Installation:** The FastenMaster® FrameFAST® Fasteners shall be installed in accordance with the manufacturer's published installation instructions, this evaluation report, and the codes mentioned in Section 1.1 of this report. In some applications, the FrameFAST installation tool or installation guide may be used to attain the proper installation angle and end/edge distances. Edge distances, end distances, and fastener spacings shall be sufficient to prevent splitting of the wood, or as required by Table 4 of this report, whichever is more restrictive. The underside of the fastener head shall be installed flush with the surface of the framing member being connected using the drive bit included with the FrameFAST® Fasteners.

## 5.0 LIMITATIONS

Use of the FastenMaster® FrameFAST® Fastener recognized in this report is subject to the following limitations:

**5.1** The fasteners shall be manufactured, identified, and installed in accordance with this report, the manufacturer's published installation instructions, and the applicable code. A copy of the manufacturer's published installation instructions shall be available at the job site during installation. Where conflicts occur, the more restrictive shall prevail.

**5.2** Calculations and details showing compliance with this report shall be submitted to the building official. The

calculations and details shall be prepared by a registered design professional where required by the statutes of the jurisdiction in which the project is to be constructed.

**5.3** Connections shall be designed using all applicable load reduction adjustment factors as noted in Tables 2 and 3 of this report and the applicable codes.

**5.4** Use of FastenMaster® FrameFAST® Fasteners in wet service conditions is beyond the scope of this report.

**5.5** Use of FastenMaster® FrameFAST® Fasteners in locations exposed to saltwater or saltwater spray is beyond the scope of this report.

**5.6** FastenMaster® FrameFAST® Fasteners are produced by OMG, Inc. in Agawam, MA.

## 6.0 SUBSTANTIATING DATA

**6.1** Data in accordance with Acceptance Criteria for Dowel-Type Threaded Fasteners Used in Wood (ICC-ES AC233).

**6.2** Data in accordance with Acceptance Criteria for Corrosion-Resistant Fasteners and Evaluation of Corrosion Effects of Wood Treatments (ICC-ES AC257).

**6.3** Test reports are from laboratories in compliance with ISO/IEC 17025.

## 7.0 IDENTIFICATION

The packaging for the FastenMaster® FrameFAST® Fasteners is labeled with the manufacturer's name (OMG, Inc.), the product name (FastenMaster® FrameFAST® Fasteners), the fastener designation, and the evaluation report number (ER-719). The Mark of Conformity may also be used as shown below:



IAPMO UES ER-719

## 8.0 STATEMENT OF RECOGNITION

This evaluation report describes the results of research completed by IAPMO Uniform Evaluation Service on FastenMaster® FrameFAST® Fasteners to assess conformance to the codes shown in Section 1.1 of this report and serves as documentation of the product certification. Products are manufactured at the location noted in Section 5.6 of this report under a quality control program with periodic inspections under the supervision of IAPMO UES.

For additional information about this evaluation report please visit [www.uniform-es.org](http://www.uniform-es.org) or email us at [info@uniform-es.org](mailto:info@uniform-es.org)

**TABLE 1 – Fastener Dimensions and Strengths**

Fastener Designation	Screw Specifications (inches)						Nominal Bending Yield Strength (psi) <sup>3</sup>	Allowable Fastener Strength (lbf)	
	Overall Length <sup>1</sup>	Thread Length <sup>2</sup>	Root Diameter	Shank Diameter	Outside Thread Diameter	Head Diameter, D <sub>H</sub>		Tensile	Shear
FMFF006	6.0	5.0	0.172	0.188	0.260	0.300	185,600	1,290	785

For SI: 1 inch = 25.4 mm, 1 psi = 6.9 kPa, lbf = 4.4 N

<sup>1</sup>. Fastener designed with countersinking type head; the overall fastener length is measured from the top of the head to the bottom of the tip.

<sup>2</sup>. Thread length includes tapered tip, as exhibited in Figure 1 of this report.

<sup>3</sup>. Bending yield strength was determined in accordance with methods specified in ASTM F1575 and based on the root diameter.

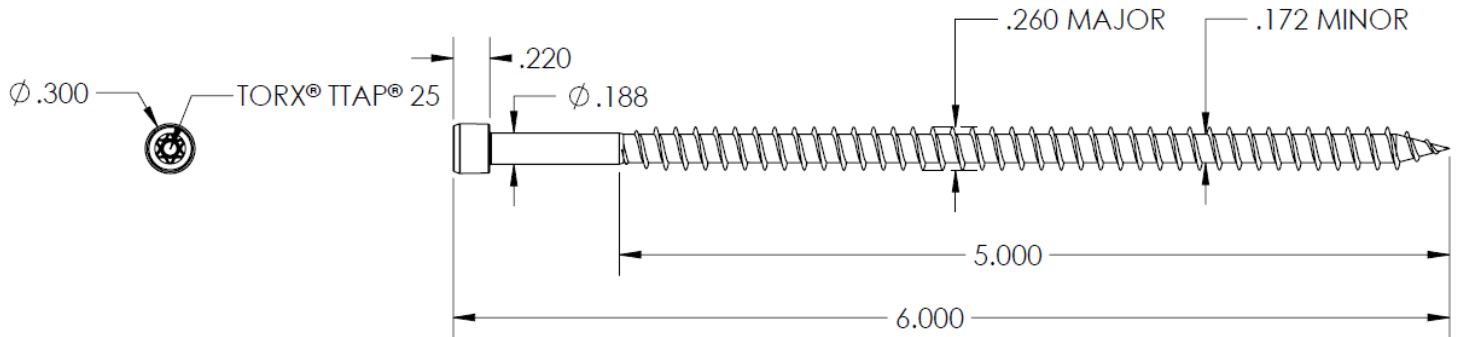

**FIGURE 1: FastenMaster® FrameFAST®**



**TABLE 2 – Reference Withdrawal and Pull-Through Design Values for Wood-to-Wood Connections** <sup>1,2,6</sup>

Fastener Designation	Fastener Length	Thread Length	Main Member	Withdrawal Design Value “W” (lb/in) <sup>3</sup>			Pull-Through Design Values (lb/in) <sup>4</sup>		
				Wood Species and Specific Gravity (SG) <sup>5</sup>					
				SP (0.55)	DF (0.50)	SPF (0.42)	SP (0.55)	DF (0.50)	SPF (0.42)
FMFF006	6.0	5.0	2 x Face	188	194	159	215	228	148
			2 x Edge	198	206	170	224	208	165
			2 x End	173	172	158	172	172	140

For SI: 1 inch = 25.4 mm, lbf = 4.45N

- Values shall be multiplied by all applicable adjustment factors as set forth in the ANSI/AWC NDS.
- The reference withdrawal and pull-through design values are in pounds per inch of the thread penetration into the main member and side member, respectively.
- The reference withdrawal design values shall be multiplied by the length of thread penetration in the main member. Length includes tapered tip.
- The reference pull-through design values shall be multiplied by the length of thread penetration in the side member, which may be calculated as overall fastener length in side member minus 1-inch unthreaded shank including the head.
- Specific Gravity shall be the assigned specific gravity for sawn lumber per Table 12.3.3A or 12.3.3B of the 2018 and 2015 ANSI/AWC NDS (Table 11.3.3A or 11.3.3B of the 2012 ANSI/AWC NDS).
- The allowable tensile strength of the fasteners shall not be exceeded.

**TABLE 3 – Reference Lateral (Z) Design Values for Wood-to-Wood Connections** <sup>1,2,3,4</sup>

Fastener Designation	Fastener Length	Thread Length	Side Member	Main Member	Lateral Design Value (Z) for Single Shear Two Member Connections (lbs)					
					Parallel to Grain in SG <sup>5</sup>			Perpendicular in SG <sup>6</sup>		
					SP (0.55)	DF (0.50)	SPF (0.42)	SP (0.55)	DF (0.50)	SPF (0.42)
FMFF006	6.0	5.0	(2) 2 x Face	2 x Edge	290	294	230	168	185	154
			2 x Face	2 x End				158	146	111
			(2) 2 x Face	2 x End				167	202	156

For SI: 1 inch = 25.4 mm, lbf = 4.45N

- Values shall be multiplied by all applicable adjustment factors as set forth in the ANSI/AWC NDS.
- Minimum fastener penetration into the main member shall be 1 ½-inches.
- Specific Gravity shall be the assigned specific gravity for sawn lumber per Table 12.3.3A or 12.3.3B of the 2018 and 2015 ANSI/AWC NDS (Table 11.3.3A or 11.3.3B of the 2012 ANSI/AWC NDS).
- The allowable tensile strength of the fasteners shall not be exceeded.
- Parallel to grain loading in the side member and parallel to grain loading in the main member.
- Perpendicular to grain loading in the side member and perpendicular to grain loading in the main member.



**TABLE 4 – Connection Geometry Using FrameFAST® Fasteners**

CONDITION		DISTANCE OR SPACING (inches) <sup>1</sup>
Minimum end distance	Loading parallel to grain	3
	Loading perpendicular to grain	3
Minimum edge distance	Loading parallel to grain	¾
	Loading perpendicular to grain	¾
Minimum spacing between in-line fasteners in a row	Loading parallel to grain	4
	Loading perpendicular to grain	3½
Minimum spacing between staggered rows	Perpendicular to grain direction	1¾
	Parallel to grain direction	¾

For SI: 1 inch = 25.4 mm

<sup>1</sup>End distances, edge distances, and fastener spacing shall be sufficient to prevent splitting of the wood, or as required by this table, whichever is the more restrictive.

**TABLE 5 – Exposure Conditions for FrameFAST® Fasteners**

EXPOSURE CONDITION	TYPICAL APPLICATIONS	RECOGNITION LIMITATIONS
1	Treated wood in dry use applications	Limited to use where the equilibrium moisture content of the chemically treated wood meets the dry service conditions as described in the ANSI/AWC NDS.
3	General Construction	Limited to freshwater and chemically treated wood exposure. The fasteners are not for use under saltwater exposure.



## CITY OF LOS ANGELES SUPPLEMENT

### FASTENMASTER® FRAMEFAST® FASTENERS

OMG, INC.  
153 Bowles Road  
Agawam, MA 01001  
(800) 518-3569  
[www.olyfast.com](http://www.olyfast.com)  
[www.fastenmaster.com](http://www.fastenmaster.com)

CSI Division: 06 00 00– Wood, Plastics, and Composites  
CSI Section: 06 05 23 – Wood, Plastic, and Composite  
Fastenings

#### 1.0 RECOGNITION

FastenMaster® FrameFAST® Fasteners recognized in ER-719 and this supplemental report have been evaluated for use as dowel-type threaded fasteners used for wood-to-wood connections. The fasteners have been evaluated for structural and corrosion resistance performance properties, subject to the requirements in ER-719 and this supplemental report. The FastenMaster® FrameFAST® Fasteners comply with the intent of the provisions of the following codes and regulations:

- 2023 City of Los Angeles Building Code (LABC)
- 2023 City of Los Angeles Residential Code (LARC)

#### 2.0 LIMITATIONS

Use of the FastenMaster® FrameFAST® Fasteners recognized in ER-719 and this report supplement is subject to the following limitations in addition to the limitations shown in ER-719:

**2.1** FastenMaster® FrameFAST® Fasteners shall be installed in accordance with the manufacturer’s published installation instructions and ER-719.

**2.2** Prior to installation, calculations and details demonstrating compliance with the FastenMaster® FrameFAST® Fasteners in ER-719 and the LABC or LARC shall be submitted to the structural plan check section for review and approval.

**2.3** The calculations shall be prepared, stamped, and signed by a California registered design professional.

**2.4** The design, installation, and inspection shall be in accordance with LABC Chapters 16 and 17, as applicable, due to local amendments to these chapters.

**2.5** Reference lateral and withdrawal design values in ER-719 are for ASD and shall be multiplied by all applicable adjustment factors specified in the ANSI/AWC NDS.

**2.6** Structural members forming the connection shall be designed in accordance with the LABC.

**2.7** When designing a connection, the structural members shall be checked for load-carrying capacity in accordance with Section 11.1.2 of ANSI/AWC NDS 2018.

**2.8** This supplement expires concurrently with ER-719.

For additional information about this evaluation report please visit [www.uniform-es.org](http://www.uniform-es.org) or email us at [info@uniform-es.org](mailto:info@uniform-es.org)





## FLORIDA SUPPLEMENT

### FASTENMASTER® FRAMEFAST® FASTENERS

#### OMG, INC.

153 Bowles Road  
Agawam, MA 01001  
(800) 518-3569

[www.olyfast.com](http://www.olyfast.com)

[www.fastenmaster.com](http://www.fastenmaster.com)

CSI Division: 06 00 00– Wood, Plastics, and Composites  
CSI Section: 06 05 23 – Wood, Plastic, and Composite  
Fastenings

#### 1.0 RECOGNITION

The FastenMaster® FrameFAST® Fasteners recognized in ER-719 and this supplemental report have been evaluated for use as dowel-type threaded fasteners used for wood-to-wood connections. The fasteners have been evaluated for structural performance properties, subject to the requirements in ER-719 and this supplemental report. The FastenMaster® FrameFAST® Fasteners comply with the intent of the provisions of the following codes and regulations:

- 2023 Florida Building Code, Building (FBC, Building)
- 2023 Florida Building Code, Residential (FBC, Residential)

#### 2.0 LIMITATIONS

Use of the FastenMaster® FrameFAST® Fasteners recognized in ER-719 and this report supplement is subject to the following limitations in addition to the limitations shown in ER-719:

**2.1** The design and installation of FastenMaster® FrameFAST® Fasteners recognized in this supplement shall be in accordance with the 2021 International Building Code and the 2021 International Residential Code as described in ER-719.

**2.2** Load combinations shall be in accordance with Sections 1605.1 or 1605.2 of the FBC, Building, as applicable.

**2.3** The use of FastenMaster® FrameFAST® Fasteners recognized with the High-velocity Hurricane Zone (HVHZ) is beyond the scope of this report.

**2.4** FastenMaster® FrameFAST® Fasteners shall be manufactured, identified, and installed in accordance with ER-719 and the manufacturer's published installation instructions. A copy of the manufacturer's published installation instructions shall be available at the job site

during installation. Where conflicts occur, the more restrictive shall prevail.

**2.5** For products falling under Section (5)(d) of Florida Rule 61G20-3.008, verification is required that the report holder's quality assurance program is audited by a quality assurance entity, approved by the Florida Building Commission (or the building official when the report holder does not possess an approval by the Commission), to provide oversight and determine that the products are being manufactured as described in this evaluation report to establish continual product performance.

**2.6** This supplement expires concurrently with ER-719.

For additional information about this evaluation report please visit [www.uniform-es.org](http://www.uniform-es.org) or email us at [info@uniform-es.org](mailto:info@uniform-es.org)