



### EVALUATION SUBJECT:

**FASTENMASTER® FLATLOK®  
FASTENERS**

### REPORT HOLDER:

**OMG, INC.**  
**153 Bowles Road**  
**Agawam, MA 01001**  
**(800) 518-3569**  
[www.olyfast.com](http://www.olyfast.com)  
[www.fastenmaster.com](http://www.fastenmaster.com)

**CSI Division: 06 00 00 – Wood, Plastics, and Composites**  
**CSI Section: 06 05 23 – Wood, Plastic, and Composite Fastenings**

### 1.0 SCOPE OF EVALUATION

#### 1.1 Compliance to the following codes & regulations:

- 2018, 2015, and 2012 International Building Code® (IBC)
- 2018, 2015, and 2012 International Residential Code® (IRC)
- 2020 City of Los Angeles Building Code (LABC) – attached supplement
- 2020 City of Los Angeles Residential Code (LARC) – attached -supplement

#### 1.2 Evaluated in accordance with:

- ICC-ES AC233

#### 1.3 Properties assessed:

- Structural

### 2.0 PRODUCT USE

The FastenMaster® FlatLOK® Fasteners are used as dowel-type threaded fasteners used for wood-to-wood and engineered wood connections.

### 3.0 PRODUCT DESCRIPTION

**3.1 General:** The FastenMaster® FlatLOK® Fasteners described in this report are partially rolled-threaded and have a proprietary point as shown in Figure 1 of this report. The fasteners are available in multiple lengths as described in Table 1 of this report.

### 3.2 Materials

**3.2.1 FlatLOK® Fasteners:** The FlatLOK® Fasteners are produced from Grade 1022 or Grade 10B21 carbon steel complying with ASTM A510-13. The fasteners are produced using a cold-forming process followed by heat treatment.

**3.2.2 Wood Members:** Wood side and main members shall consist of sawn lumber with a specific gravity of 0.42 to 0.55, or (LVL and LSL) having a minimum equivalent specific gravity as specified in Tables 2, 4, 5, and 6 of this report. The combined thickness of the main and side members shall be equal to or greater than the fastener length.

### 4.0 DESIGN AND INSTALLATION

#### 4.1 Design:

**4.1.1 General:** The connections using FlatLOK® Fasteners shall be designed in accordance with the IBC or IRC. Reference withdrawal, lateral, and pull-through design values in this report are for allowable stress design (ASD) and shall be multiplied by the applicable adjustment factors specified in the ANSI/AWC NDS (NDS) and this report to determine adjusted design values.

The allowable load for a single-fastener connection in which the fastener is subject to tension is the least of: (a) the reference withdrawal design value given in Table 2 of this report, adjusted by all applicable adjustment factors; (b) the reference head pull-through design value given in Table 6 of this report, adjusted by all applicable adjustment factors; and (c) the allowable fastener tension strength given in Table 1 of this report.

The allowable lateral load for a single-fastener connection is the lesser of: (a) the reference lateral design values given in Tables 3, 4, and 5 of this report, adjusted by all applicable adjustment factors, and (b) the allowable fastener shear strength given in Table 1 of this report.

Where the fasteners are subject to combined lateral and withdrawal loads, connections shall be designed in accordance with Section 12.4.1 of the 2018 or 2015 NDS, or Section 11.4.1 of the 2012 NDS, as applicable.

Connections containing multiple fasteners shall be designed in accordance with Sections 11.2.2 and 12.6 of the 2018 or 2015 NDS, or Sections 10.2.2 and 11.6 of the 2012 NDS, as applicable. When designing a connection, the structural members shall be checked for load-carrying capacity in accordance with Section 11.1.2 of the 2018 or 2015 NDS, or Section 10.1.2 of the 2012 NDS, as applicable, and local





stresses within the connection shall be checked against Appendix E in the NDS to ensure the capacity of the connection and fastener group.

**4.1.2 Withdrawal:** Reference withdrawal design values for FastenMaster® FlatLOK® Fasteners are given in Table 2 of this report. Loads are given in pounds with a minimum penetration into the main member of 1 ½-inches (38.1 mm) for face and edge grain and 2 inches (50.8 mm) for end grain.

**4.1.3 Lateral:** Reference lateral design values for FastenMaster® FlatLOK® Fasteners for single shear wood-to-wood connections loaded perpendicular- ( $Z_{perp}$ ) or parallel-to-grain ( $Z_{para}$ ) are given in Tables 3, 4, and 5 of this report.

**4.1.4 Pull-Through:** Reference pull-through design values for FastenMaster® FlatLOK® Fasteners are given in Table 6 of this report.

**4.2 Installation:** FastenMaster® FlatLOK® Fasteners shall be installed in accordance with the manufacturer’s published installation instructions, this evaluation report, and the codes mentioned in Section 1.1 of this report, using a low-speed drill. Edge distances, end distances, and fastener spacing of shall be sufficient to prevent splitting of the wood, or as required by Table 7 of this report, whichever is more restrictive. The top of the fastener head shall be installed flush with the surface of the framing member being connected using the drilling bit included with the FastenMaster® FlatLOK® Fasteners.

## 5.0 LIMITATIONS

Use of the FastenMaster® FlatLOK® Fasteners recognized in this report is subject to the following limitations:

**5.1** The fasteners shall be manufactured, identified, and installed in accordance with this report, the manufacturer’s published installation instructions, and the applicable code. A copy of the manufacturer’s published installation instructions shall be available at the jobsite during installation. Where conflicts occur, the more restrictive shall prevail.

**5.2** Calculations and details showing compliance with this report shall be submitted to the building official. The calculations and details shall be prepared by a registered design professional where required by the statutes of the AHJ in which the project is to be constructed.

**5.3** When use is in engineered wood products, the minimum fastener end and edge distances, and spacing shall be in accordance with Table 7 of this report or in accordance with the recommendations of the engineered wood product manufacturer, whichever is more restrictive.

**5.4** Connections shall be designed using all applicable load reduction adjustment factors as noted in Tables 2 through 6 of this report and the applicable codes.

**5.5** Use of FlatLOK® Fasteners in wet service conditions is beyond the scope of this report.

**5.6** Use of FlatLOK® Fasteners in outdoor applications, in chemically treated wood, or where fasteners are required to be corrosion resistant is beyond the scope of this report.

**5.7** FastenMaster® FlatLOK® Fasteners are produced by OMG, Inc. in Agawam, MA.

## 6.0 SUBSTANTIATING DATA

**6.1** Data in accordance with the ICC-ES Acceptance Criteria for Dowel-Type Threaded Fasteners Used in Wood, AC233, approved February 2020.

**6.2** Test reports are from laboratories in compliance with ISO/IEC 17025.

## 7.0 IDENTIFICATION

The packaging for the FastenMaster® FlatLOK® Fasteners is labeled with manufacturer’s name (OMG, Inc.), the product name (FastenMaster® FlatLOK® Fasteners), the fastener designation, and the evaluation report number (ER-718). The identification includes the IAPMO Uniform Evaluation Service Mark of Conformity. Either Mark of Conformity may also be used as shown below:

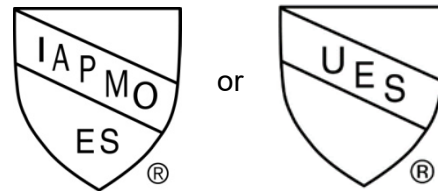

**IAPMO UES ER-718**

## 8.0 STATEMENT OF RECOGNITION

This evaluation report describes the results of research completed by IAPMO Uniform Evaluation Service on FastenMaster® FlatLOK® to assess conformance to the codes shown in Section 1.0 of this report and serves as documentation of the product certification. Products are manufactured at locations noted in Section 5.7 of this report under a quality control program with periodic inspection under the supervision of IAPMO UES.

For additional information about this evaluation report please visit [www.uniform-es.org](http://www.uniform-es.org) or email us at [info@uniform-es.org](mailto:info@uniform-es.org)

**TABLE 1 – Fastener Dimensions and Strengths**

Fastener Designation	Head Stamp	Screw Specifications (inches)						Nominal Bending Yield Strength (psi) <sup>3</sup>	Allowable Fastener Strength (lbf)	
		Overall Length <sub>1</sub>	Thread Length <sub>2</sub>	Root Diameter	Shank Diameter	Outside Thread Diameter	Head Diameter, D <sub>H</sub>		Tensile	Shear
FL278	F2.9FL	2 7/8	2.0	0.200	0.227	0.322	0.700	167,800	1,940	1,230
FL312	F3.5FL	3 1/2								
FL004	F4.0FL	4								
FL412	F4.5FL	4 1/2								
FL005	F5.0FL	5								
FL006	F6.0FL	6								
FL634	F6.75FL	6 3/4								

For SI: 1 inch = 25.4 mm, 1 psi = 6.9 kPa, lbf = 4.4 N

<sup>1</sup>. Fastener designed with countersinking type head; the overall fastener length is measured from the top of head to the tip.

<sup>2</sup>. Thread length includes tapered tip, as exhibited in Figure 1 of this report.

<sup>3</sup>. Bending yield strength was determined in accordance with methods specified in ASTM F1575 and based on the root diameter.

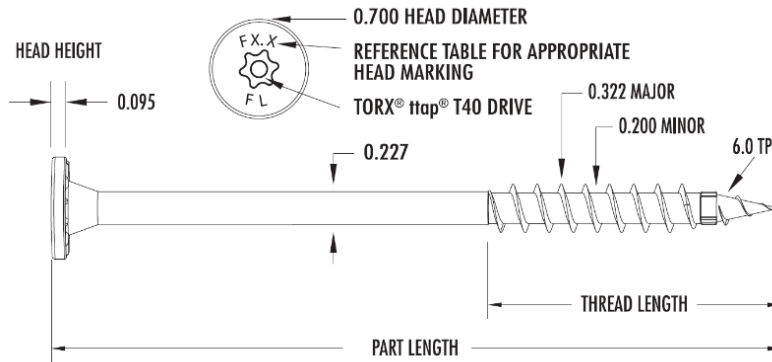

**FIGURE 1: FastenMaster® FlatLOK®**

**TABLE 2 – Reference ASD Withdrawal Design Values (W) By Wood Species <sup>1,2,6</sup>**

Thread Penetration into Main Member (in)	Fastener Orientation to Grain	Reference Withdrawal Design Values Given in Pounds for the Total Inches of Thread Penetration into the Main Member				
		Wood Species and Specific Gravity (SG) <sup>3</sup>				
		SPF (0.42)	D.Fir (0.50)	S.Pine (0.55)	LVL <sup>4</sup>	LSL <sup>5</sup>
1 ½	Face	165	240	305	295	320
	Edge	200	280	280	255	290
1 ¾	Face	195	285	365	350	385
	Edge	240	335	335	310	345
2	Face	230	335	425	410	450
	Edge	280	390	390	360	405
	End	175	295	285	---	---

For SI: 1 inch = 25.4 mm, lbf = 4.45N

<sup>1</sup> Values shall be multiplied by all applicable load reduction adjustment factors as set forth in the NDS.

<sup>2</sup> Minimum penetration into the main member, 1 ½-inches for face and edge grain and 2 inches for end grain.

<sup>3</sup> Specific Gravity shall be the assigned specific gravity for sawn lumber per Table 12.3.3A or 12.3.3B of the 2018 and 2015 NDS (Table 11.3.3A or 11.3.3B of the 2012 NDS).

<sup>4</sup> For Weyerhaeuser Microllam<sup>®</sup> LVL having a minimum 2.0E grade designation with a minimum equivalent specific gravity of 0.50 in face and edge grain.

<sup>5</sup> For LP<sup>®</sup> SolidStart<sup>®</sup> LSL having a minimum 1.35E grade designation with a minimum equivalent specific gravity of 0.46 in edge grain and 0.50 in face grain.

<sup>6</sup> The allowable tensile strength of the fasteners shall not be exceeded.

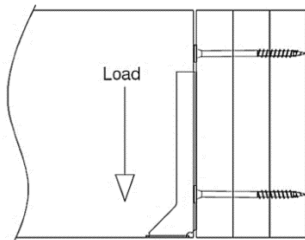

**FIGURE 2a – Head Side Loading**

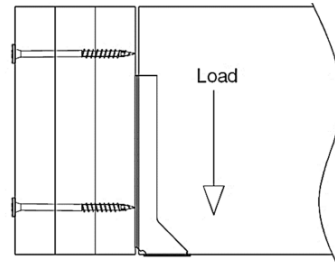

**FIGURE 2b – Point Side Loading**

**FIGURE 2 – Lateral Loading of Multi-ply Members Joined Using FlatLOK<sup>®</sup> Fasteners**

**Notes to Figure 2 and Tables 3 and 4:**

- In multi-ply members, the capacity of the connection depends on the location of the load in relation to the fastener. The capacity of the connection is highest when the load is acting first on the ply that is held by the head-end of the screw, as shown in Figure 2a above (Head Side Loading), and lowest when acting first on the ply that is held by the thread-end of the screw, as shown in Figure 2b above (Point Side Loading).
- Table 3 of this report gives lateral design values for FastenMaster<sup>®</sup> FlatLOK<sup>®</sup> Fasteners used in Head and Point Side Loading of sawn lumber multi-ply members.
- Table 4 of this report gives lateral design values for FastenMaster<sup>®</sup> FlatLOK<sup>®</sup> Fasteners used in Head and Point Side Loading of engineered wood multi-ply members.
- Where fastener orientation is unknown, the values for Point Side Loading shall be used.
- Connection capacities for Head and Point Side Loading may be averaged where members are joined using FlatLOK<sup>®</sup> Fasteners installed equally from both sides.



**TABLE 3 – Reference Lateral (Z) Design Values for Wood-To-Wood Connections for Sawn Lumber in Applications with Head Side and Point Side Loading<sup>1,3</sup>**

Fastener Designation	Head Stamp	Fastener Length (inches)	Loaded Member Thickness, Ts (inches)	Fastener Penetration into Remaining Plies (inches)	Reference Lateral Design Value (Z) for Specific Gravities (lb) <sup>2</sup>					
					SPF (SG=0.42)		DF (SG=0.50)		SP (SG=0.55)	
<b>Head Side Loading<sup>4</sup></b>					<b>Z<sub>para</sub></b>	<b>Z<sub>perp</sub></b>	<b>Z<sub>para</sub></b>	<b>Z<sub>perp</sub></b>	<b>Z<sub>para</sub></b>	<b>Z<sub>perp</sub></b>
FL278	F2.9FL	2- 7/8	1 ½	1 ¾	150	200	235	240	270	270
FL312	F3.5FL	3 ½	1 ½	2	150	200	235	240	270	270
FL004	F4.0FL	4	1 ½	2 ½	150	200	235	240	270	270
FL412	F4.5FL	4 ½	1 ½	3	245	320	350	480	440	550
FL005	F5.0FL	5	1 ½	3 ½	245	320	350	480	440	550
FL006	F6.0FL	6	1 ½	4 ½	245	320	350	480	440	550
FL634	F6.75FL	6 ¾	1 ½	5 ¼	245	320	350	480	440	550
<b>Point Side Loading<sup>4</sup></b>					<b>Z<sub>para</sub></b>	<b>Z<sub>perp</sub></b>	<b>Z<sub>para</sub></b>	<b>Z<sub>perp</sub></b>	<b>Z<sub>para</sub></b>	<b>Z<sub>perp</sub></b>
FL004	F4.0FL	4 ½	1 ½	3	---	200	----	260	----	290
FL006	F6.0FL	6	1 ½	4 ½	---	200	---	260	---	290

For SI: 1 inch = 25.4 mm, 1 lbf = 4.45N

- <sup>1</sup>. Reference values shall be multiplied by all applicable load reduction adjustment factors as set forth in the NDS.
- <sup>2</sup>. Specific Gravity shall be the assigned specific gravity for sawn lumber per Table 12.3.3A or 12.3.3B of the 2018 and 2015 NDS (Table 11.3.3A or 11.3.3B of the 2012 NDS), respectively, or the engineered wood product equivalent specific gravity given in the applicable evaluation report.
- <sup>3</sup>. Fasteners shall be installed straight into the side grain of the wood main member with the fastener axis at a 90-degree angle to the wood fibers.
- <sup>4</sup>. The loaded member is the member held by the head in Head Side Loading, and by the point in Point Side Loading. (Figures 2a and 2b)



**TABLE 4 – Reference Lateral (Z) Design Values for Wood-To-Wood Connections for Engineered Wood Products in Applications with Head Side and Point Side Loading <sup>1,5</sup>**

Fastener Designation	Head Stamp	Fastener Length (inches)	Loaded Member Thickness, Ts (inches)	Fastener Penetration into Remaining Plies (inches)	Reference Lateral Design Value (Z) for Specific Gravities (lb) <sup>2</sup>			
					LVL <sup>3</sup>		LSL <sup>4</sup>	
<b>Head Side Loading<sup>6</sup></b>					Z <sub>para</sub>	Z <sub>perp</sub>	Z <sub>para</sub>	Z <sub>perp</sub>
FL278	F2.9FL	2- 7/8	1 1/4	1 5/8	235	375	235	435
FL312	F3.5FL	3 1/2	1 3/4	1 3/4	235	375	235	435
FL005	F5.0FL	5	1 3/4	3 1/4	350	560	350	480
FL006	F6.0FL	6	1 3/4	4 1/4	350	560	350	480
FL634	F6.75FL	6 3/4	1 3/4	5	350	560	350	480
<b>Point Side Loading<sup>6</sup></b>					Z <sub>para</sub>	Z <sub>perp</sub>	Z <sub>para</sub>	Z <sub>perp</sub>
FL312	F3.5FL	3 1/2	1 3/4	1 3/4	235	330	235	260
FL005	F5.0FL	5	1 3/4	3 1/4	235	330	235	260
FL006	F6.0FL	6 3/4	1 3/4	5	235	330	235	260
FL634	F6.75FL	6 3/4	1 3/4	5	235	330	235	260

For SI: 1 inch = 25.4 mm, 1 lbf = 4.45N

<sup>1</sup> Values shall be multiplied by all applicable load reduction adjustment factors as set forth in the NDS.

<sup>2</sup> Specific Gravity shall be the assigned specific gravity for sawn lumber per Table 12.3.3A or 12.3.3B of the 2018 and 2015 NDS (Table 11.3.3A or 11.3.3B of the 2012 NDS).

<sup>3</sup> For Weyerhaeuser Microllam<sup>®</sup> LVL having a minimum 2.0E grade designation has a minimum equivalent specific gravity of 0.5 in face grain.

<sup>4</sup> For LP<sup>®</sup> SolidStart<sup>®</sup> LSL having a minimum 1.35E grade designation with a minimum equivalent specific gravity of 0.55 in face grain .

<sup>5</sup> Fasteners shall be installed straight into the side grain of the wood main member with the fastener axis at a 90-degree angle to the wood fibers.

<sup>6</sup> The loaded member is the member held by the head in Head Side Loading, and by the point in Point Side Loading. (Figures 2a and 2b)



**TABLE 5 – Reference Lateral Design Values for Sawn and Engineered Wood Products in Edge Grain <sup>1</sup>**

Fastener Designation	Head Stamp	Fastener Length (inches)	Side Member Thickness (inches)	Minimum Fastener Penetration into the Main Member	Reference Lateral Design Value (Z) for Specific Gravities (lb) <sup>3</sup>			
					SPF (SG=0.42)	DF (SG=0.50)	SP (SG=0.55)	LSL <sup>2</sup>
FL006	F6.0FL	6	3 ½	2 ½	235	300	285	225

For SI: 1 inch = 25.4 mm, 1 lbf = 4.45N

<sup>1</sup>. Values shall be multiplied by all applicable load reduction adjustment factors as set forth in the NDS.

<sup>2</sup>. For LP<sup>®</sup> SolidStart<sup>®</sup> LSL having a minimum 1.35E grade designation with a minimum equivalent specific gravity of 0.5 in edge grain.

<sup>3</sup>. The reference lateral design values were determined by testing.

**TABLE 6 – Reference Pull-Through Design Values Loads (lbf) <sup>1</sup>**

Minimum Side Member Thickness (inches)	Reference Pull-Through Design Values (lb) for Specific Gravities (lb) <sup>2</sup>				
	SPF (SG=0.42)	DF (SG=0.50)	SP SG=0.55	LVL <sup>3</sup>	LSL <sup>4</sup>
1 ½	395	530	595	650	750

For SI: 1 inch = 25.4 mm, 1 lbf = 4.45N

<sup>1</sup>. Values shall be multiplied by all applicable load reduction adjustment factors as set forth in the NDS.

<sup>2</sup>. Specific Gravity shall be the assigned specific gravity for sawn lumber per Table 12.3.3A or 12.3.3B of the 2018 and 2015 NDS (Table 11.3.3A or 11.3.3B of the 2012 NDS).

<sup>3</sup>. For Weyerhaeuser Microllam<sup>®</sup> LVL having a minimum 2.0E grade designation has a minimum equivalent specific gravity of 0.5 in face grain.

<sup>4</sup>. For LP<sup>®</sup> SolidStart<sup>®</sup> LSL having a minimum 1.35E grade designation with a minimum equivalent specific gravity of 0.5 in face grain.

**TABLE 7 – Minimum Edge Distance, End Distance, and Spacing Requirements for Connections Using FlatLOK® Fasteners**

CONDITION			DISTANCE OR SPACING (inches) <sup>1</sup>		
			Face	Edge	End
Minimum end distance	Loading parallel to grain	A	6	6	--
	Loading perpendicular to grain		6	6	--
Minimum edge distance	Loading parallel to grain	B	1 ¾	¾	¾
	Loading perpendicular to grain		1 ¾	¾	¾
Minimum spacing between in-line fasteners in a row	Loading parallel to grain	C	3 ½	3 ½	3 ½
	Loading perpendicular to grain	D	3 ½	--	--
Minimum spacing between staggered rows	Perpendicular to grain direction	E	5/8	--	--
	Parallel to grain direction	F	5/8	--	--

For SI: 1 inch = 25.4 mm

<sup>1</sup>: End distances, edge distances, and fastener spacing shall be sufficient to prevent splitting of the wood, or as required by this table, whichever is the more restrictive.

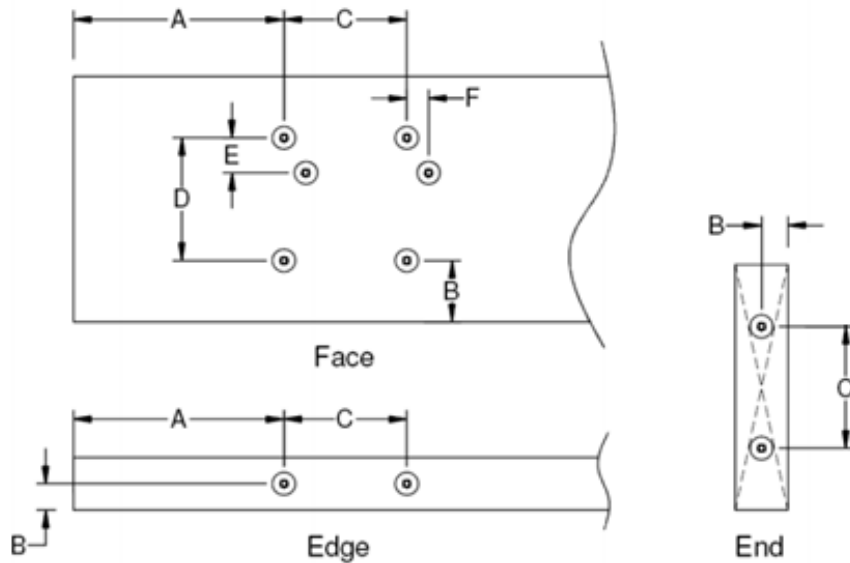

**FIGURE 3: Connection Geometry – FastenMaster® FlatLOK®**





## CITY OF LOS ANGELES SUPPLEMENT

### FASTENMASTER® FLATLOK® FASTENERS

OMG, INC.  
153 Bowles Road  
Agawam, MA 01001  
(800) 518-3569  
[www.olyfast.com](http://www.olyfast.com)  
[www.fastenmaster.com](http://www.fastenmaster.com)

CSI Division: 06 00 00 – Wood, Plastics, and Composites  
CSI Section: 06 05 23 – Wood, Plastic, and Composite  
Fastenings

#### 1.0 RECOGNITION

FastenMaster® FlatLOK® Fasteners recognized in ER-718 and this supplemental report have been evaluated for use as dowel-type threaded fasteners used for wood-to-wood connections and engineered wood connections. The fasteners have been evaluated for structural performance properties, subject to the requirements in ER-718 and this supplemental report. The FastenMaster® FlatLOK® Fasteners comply with the intent of the provisions of the following codes and regulations:

- 2020 City of Los Angeles Building Code (LABC)
- 2020 City of Los Angeles Residential Code (LARC)

#### 2.0 LIMITATIONS

Use of the FastenMaster® FlatLOK® Fasteners recognized in ER-718 and this report supplement is subject to the following limitations in addition to the limitations shown in ER-718:

2.1 FastenMaster® FlatLOK® Fasteners shall be installed in accordance with the manufacturer's published installation instructions and ER-718.

2.2 Construction details and specifications verifying compliance with the FastenMaster® FlatLOK® Fasteners shall be indicated on the approved plans by the engineer of record. The details shall be approved by the structural plan check engineer at the time of application.

2.3 Reference lateral and withdrawal design values in ER-718 are for ASD and shall be multiplied by all applicable adjustment factors specified in the ANSI/AWC NDS.

2.4 Structural members forming the connection shall be designed in accordance with the 2020 LABC.

2.5 When designing a connection, the structural members shall be checked for load-carrying capacity in accordance with Section 11.1.2 of ANSI/AWC NDS 2018.

2.6 This supplement expires concurrently with ER-718.

For additional information about this evaluation report please visit [www.uniform-es.org](http://www.uniform-es.org) or email us at [info@uniform-es.org](mailto:info@uniform-es.org)